

DATA SHEET



Description: Female Header connector.

Part No. Speed : SPFH
Project No. Speed :

Part No. customer :
Project No. customer :

Data sheet No.: DBSP 007 Drawn : Derek McGann
Revision : 8 Checked :
Date : 24.02.2016 Page : 1 of 1

Speed Electronics Ltd.
Gort Road Industrial Estate
Ennis Co. Clare Ireland
Tel: 00 353 (0)65 6869044
Fax: 00353 (0)65 6869446

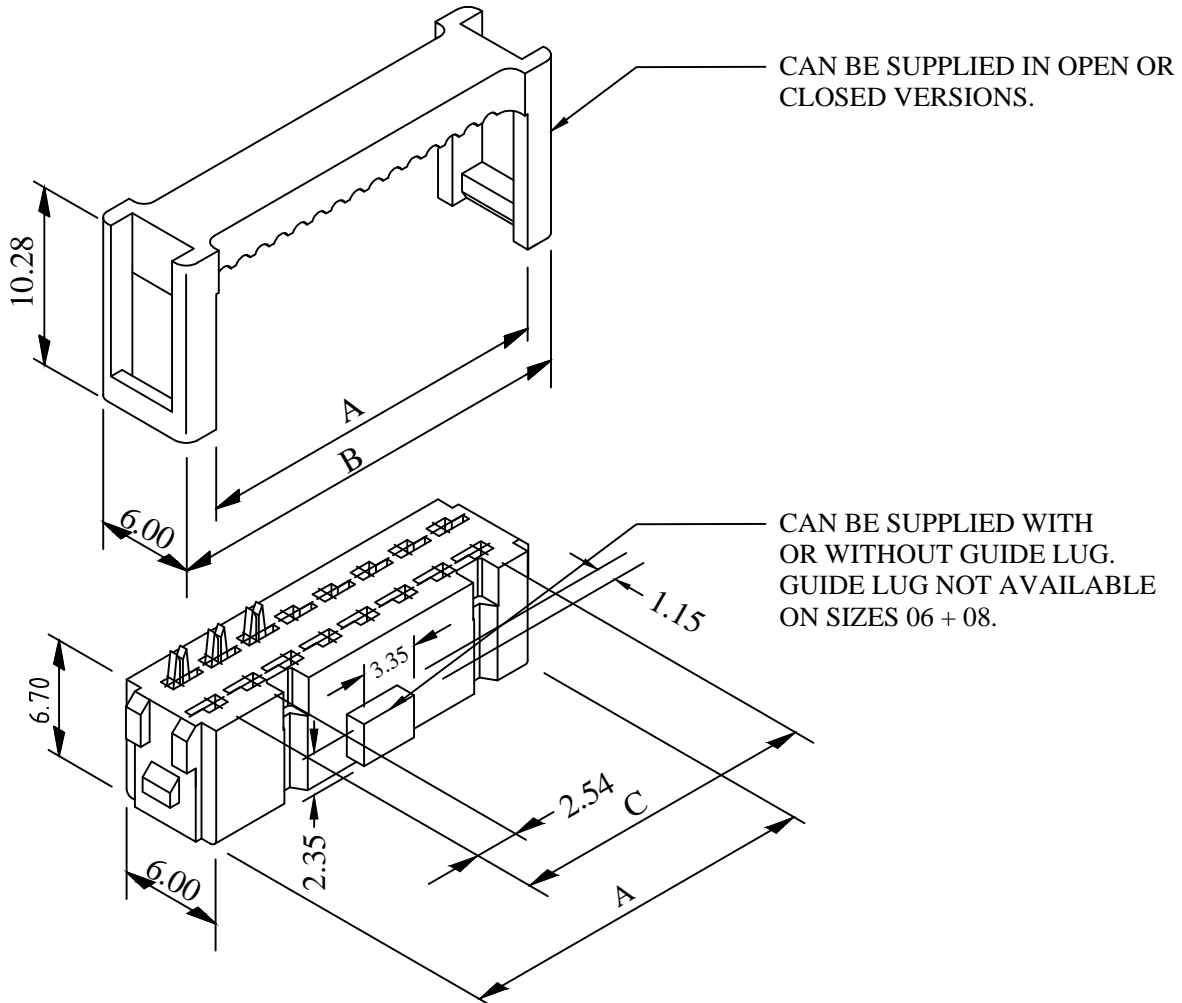

	06	08	10	14	16	20	26	34	40	50	60
A	7.38	10.18	12.68	17.78	20.28	25.38	32.98	43.18	50.78	63.48	76.18
B	12.12	14.66	17.20	22.30	24.85	29.90	37.55	47.70	55.30	68.00	80.70
C	5.08	7.62	10.16	15.24	17.78	22.86	30.48	40.64	48.26	60.96	73.66

RoHS compliant

PLATING : Nickel Base : 50µ" on full contact
Surface Finishes :
Contact Area :
3000 = RL3 : 50 Mating Cycles = 4µ" Gold.
2000 = RL2 : 250 Mating Cycles = 15µ" Gold.
1000 = RL1 : 500 Mating Cycles = 30µ" Gold.
4000 = RL4 : 50 Mating Cycles = 100µ" Tin all over

Withstanding voltage : 1000V DC or AC peak
Current rating : 1.0A
Contact resistance : 20mOhm
Insulation resistance : 5000MOhm at 100V
Normal operating temperature : -40 degree to +105 degree centigrade

Plastic Material: PBT 20% GF
Manufacturer : Bayer
Material : Pocan B4225
Product rating : UL-94 V-O
File no. : E41613

SEE SPEEDFLEX CATALOGUE FOR ORDERING DETAILS.
STRAIN RELIEF ALSO AVAILABLE FOR ALL SIZES EXCEPT 06 + 08. REQUEST DBSP 008 FOR DETAILS.